

## Semi-Automatic Turntable Stretch Wrapper

### FEATURES AND BENEFITS

#### Machine Features

- Heavy-duty, welded steel construction (no plastic panels) designed for long life
- Variable turntable speed using 1/2 hp, 90 Vdc motor with ANSI 50 chain drive system
- Up to 12 RPM rotating table can deliver 25–40 loads per hour
- Long-range photo eye for automatic load height sensing
- Top film overwrap control feature (TOC)
- Adjustable top and bottom illuminated LED wrap counters
- Magnetic proximity switches in place of mechanical limit switches
- Cycle pause feature
- Manual jog turntable control
- Eco-friendly, durable powder coating

#### Controls Hardware

- Allen-Bradley® power, control, and safety components
- Allen-Bradley® MicroLogix™ PLC
- UL/CSA approved components

#### Film Delivery System

- Variable carriage speed up to 21 feet per minute
- 1/2 hp, 90 Vdc motor with ANSI 40 chain lift drive
- Adjustable core-brake tension



High-Profile



"Quick Change"  
Film Mandrel



Low-Profile

### APPLICATIONS

- |                     |                      |                         |
|---------------------|----------------------|-------------------------|
| • Automotive        | • Consumer Goods     | • Health & Beauty       |
| • Beverage          | • Contract Packaging | • Material Handling     |
| • Building Supplies | • Food               | • Printing & Publishing |

Note: Final Layout May Vary

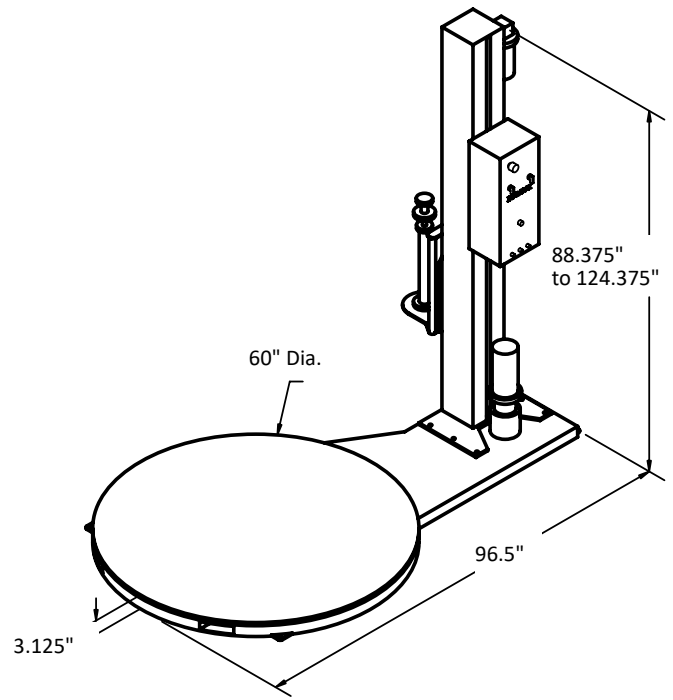
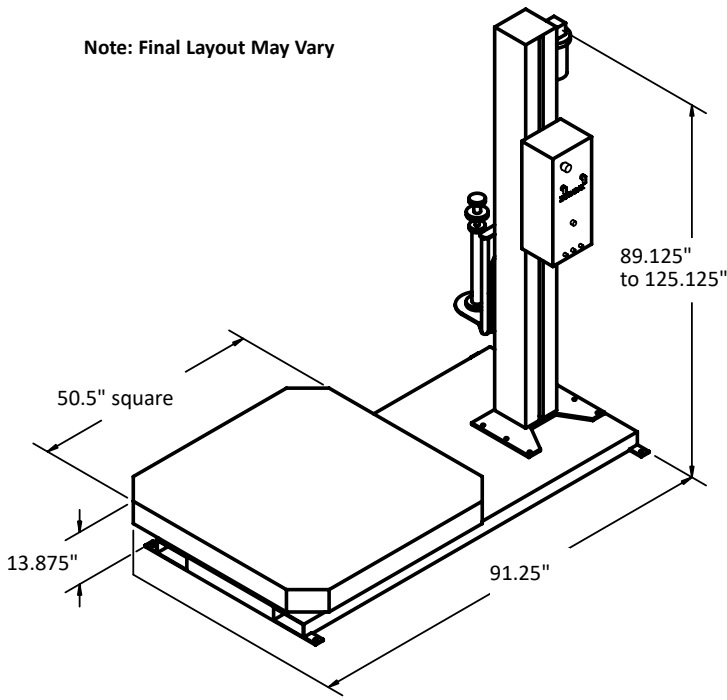

Specification	Measurement
<b>Turntable size – low-profile</b>	60" diameter (standard) 72" diameter (optional) (Larger sizes available)
<b>Turntable size – high-profile</b>	50" square (standard) 50" x 90" rectangular (option)
<b>Max. load diagonal clearance</b>	85" (standard turntable) 102" (optional turntable)
<b>Max. load weight</b>	4,000 lb. (standard)
<b>Turntable rotation speed</b>	Up to 12 RPM
<b>Loads wrapped per hour</b>	25 to 40
<b>Max load height – low-profile:</b> - Standard Tower - Optional extensions available (12, 24, and 36")	81" max. load height  93", 105", and 117" options
<b>Max load height – high-profile:</b> - Standard Tower - Optional extensions available (12", 24", and 36")	74" max load height  86", 98", and 110" options
<b>Electrical power requirements</b>	120 VAC, 1 Ph, 60 Hz, 15 A
<b>Standard shipping weight</b>	Low-profile 1,525 lb High-profile 1,260 lb

## OPTIONS

- Extended film tower for wrapping taller loads exceeding standard machine capability
- A variety of access ramps to assist loading of pallet
- Split frame construction to increase film tower clearance for oversized loads
- Cycle counter to count the actual cycles of machine operation
- Extended umbilical cords for split frame models
- Integrated scale and printer available



Variety of Access Ramps Available